

CHANNEL EXTENSION MODULES

UR-FR5000 UR-FR6000

Thank you for purchasing the UR-FR5000/UR-FR6000 CHANNEL EXTENSION MODULES. Please read these instructions and repeater's instruction manual carefully before installation and operation.

SUPPLIED ACCESSORIES

- ① DC power cable 1
- ② Control cable 1
- ③ Angles 2
- ④ Screws (M4×8 mm) 4
- ⑤ Set screws (M3×6 mm) 4
- ⑥ Tapping screws (M3×8 mm) 2

1 mm = 1/32 inch

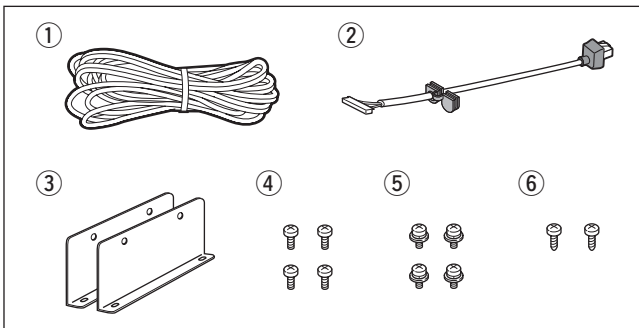

FOR CLASS B UNINTENTIONAL RADIATORS

This equipment has been tested and found to comply with the limits for a Class B digital device, pursuant to part 15 of the FCC Rules. These limits are designed to provide reasonable protection against harmful interference in a residential installation. This equipment generates, uses and can radiate radio frequency energy and, if not installed and used in accordance with the instructions, may cause harmful interference to radio communications. However, there is no guarantee that interference will not occur in a particular installation. If this equipment does cause harmful interference to radio or television reception, which can be determined by turning the equipment off and on, the user is encouraged to try to correct the interference by one or more of the following measures:

- Reorient or relocate the receiving antenna.
- Increase the separation between the equipment and receiver.
- Connect the equipment into an outlet on a circuit different from that to which the receiver is connected.
- Consult the dealer or an experienced radio/TV technician for help.

Icom, Icom Inc. and the ICOM logo are registered trademarks of Icom Incorporated (Japan) in the United States, the United Kingdom, Germany, France, Spain, Russia and/or other countries. All other products or brands are registered trademarks or trademarks of their respective holders.

OPENING CASE

- ① Remove 7 screws from top and 2 screws each from both sides of the repeater, then slide off the top cover to the direction of the arrow as illustrated below.

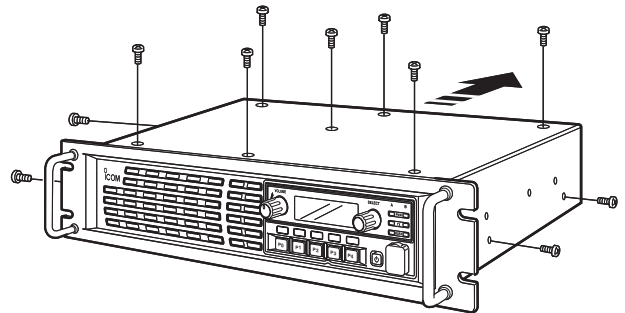

- ② Remove 3 screws from bottom and 2 screws each from both sides of the repeater.

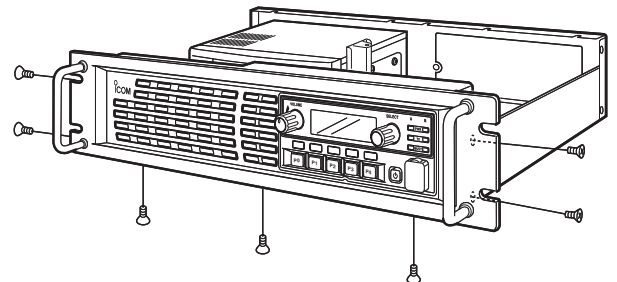

- ③ Disconnect the control cable from the channel module (original), then remove the front panel.

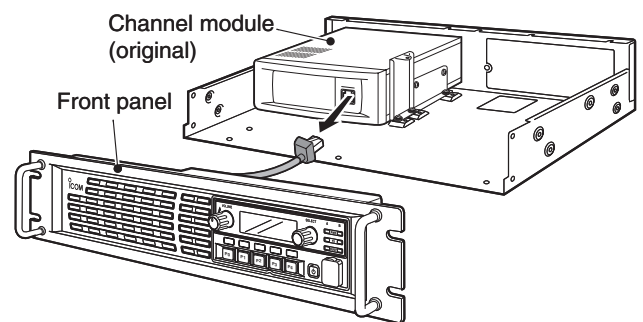

- ④ Remove 6 screws from the front panel, then remove the shielding plate and rubber seal.

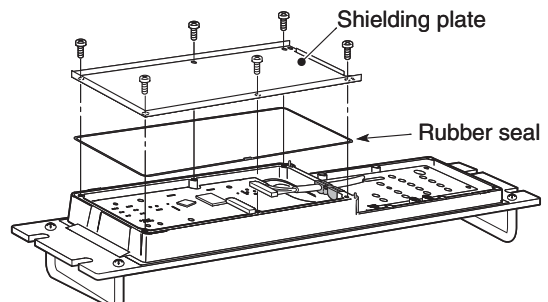

INSTALLATION

• Install the UR-FR5000 or UR-FR6000 (channel extension module)

- ① Attach the supplied angles to both sides of the channel extension module, and tighten the 2 supplied screws (M4×8) on each side.

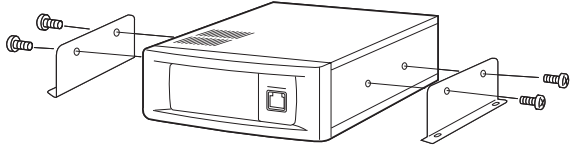

- ② Install the channel extension module using the supplied screws (Tapping screws: M3×8, Set screws: M3×6) as shown below.

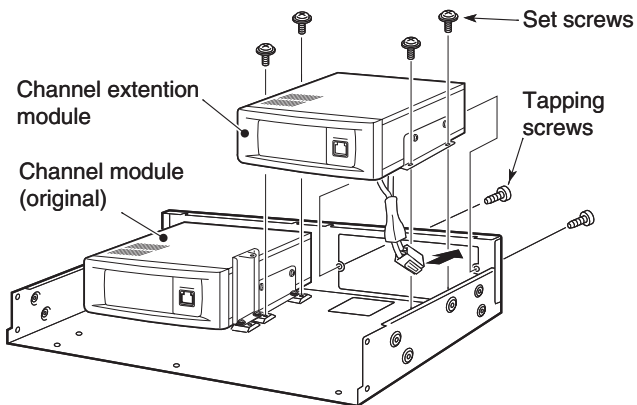

• Connect the control cable

- ① Connect the supplied control cable to J502 on the front board as shown below.
- ② Cut the rubber caps of the control panel, then insert the rubber caps to the front panel's chassis as shown below.

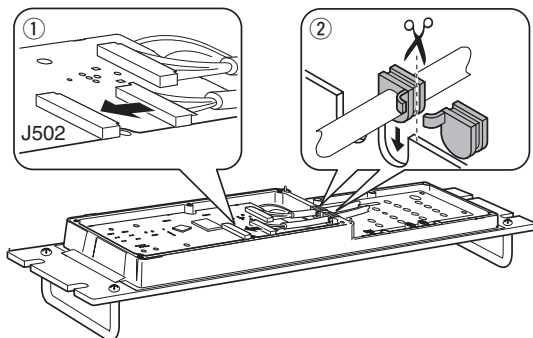

ASSEMBLE THE UNIT

- ① Replace the rubber seal and shielding plate of the front panel, then tighten the 6 screws.
 - Make sure the rubber seal is properly seated in the groove of the chassis.
 - Be sure to match the correct positions of the holes of the shielding plate and projections of the front panel's chassis.

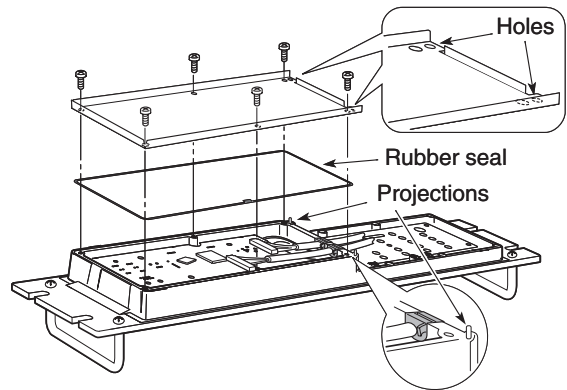

- ② Connect the control cables to the channel modules.

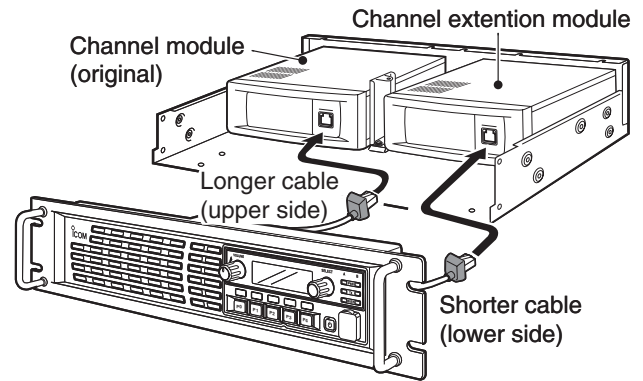

- ③ Return the front panel, top cover and screws to their original positions.

